



Vibration Separator

Advantages of the ARBO Vibration Separator:

- Simple construction
- Decreased noise and vibration
- Easy to change frequency
- Fixed output
- Economy of electric power (single phase, 110V or 220V)
- Easy to clean and replace screen
- Separate in to powder size
- Dust free material separate
- Made of AISI 304 or AISI 316L

Application Fields

- Chemistry ●
- Pharmacy ●
- Food ●
- Plastic ●
- Metal Powders ●
- Small parts ●

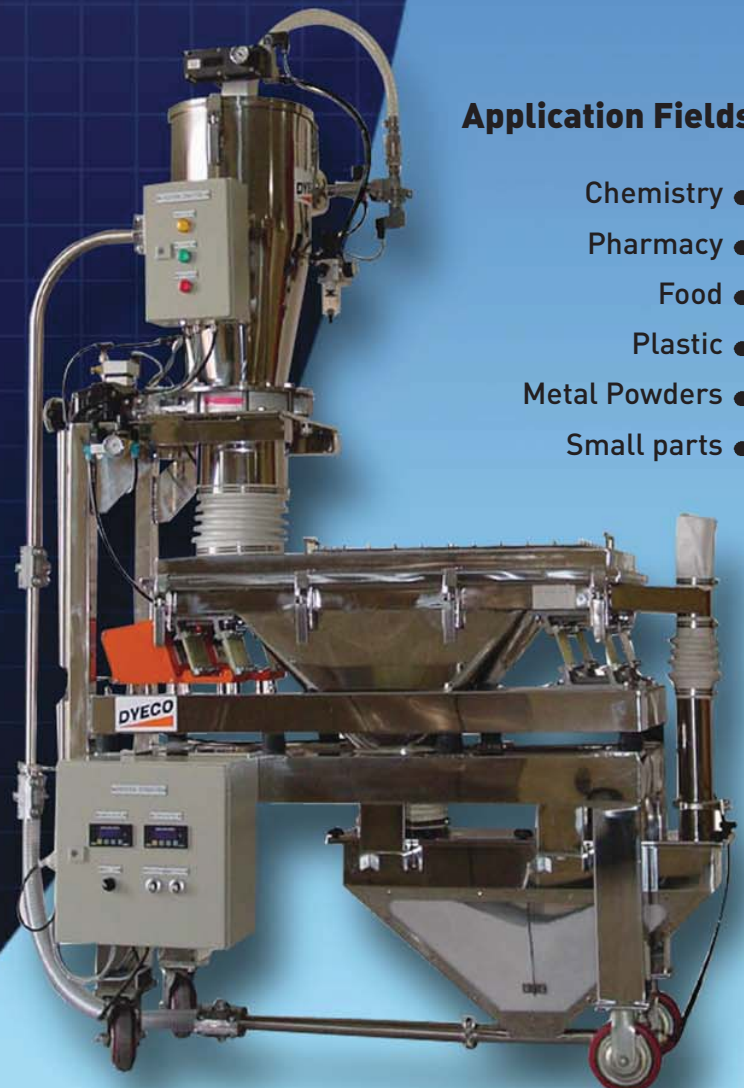

Vibration Separator

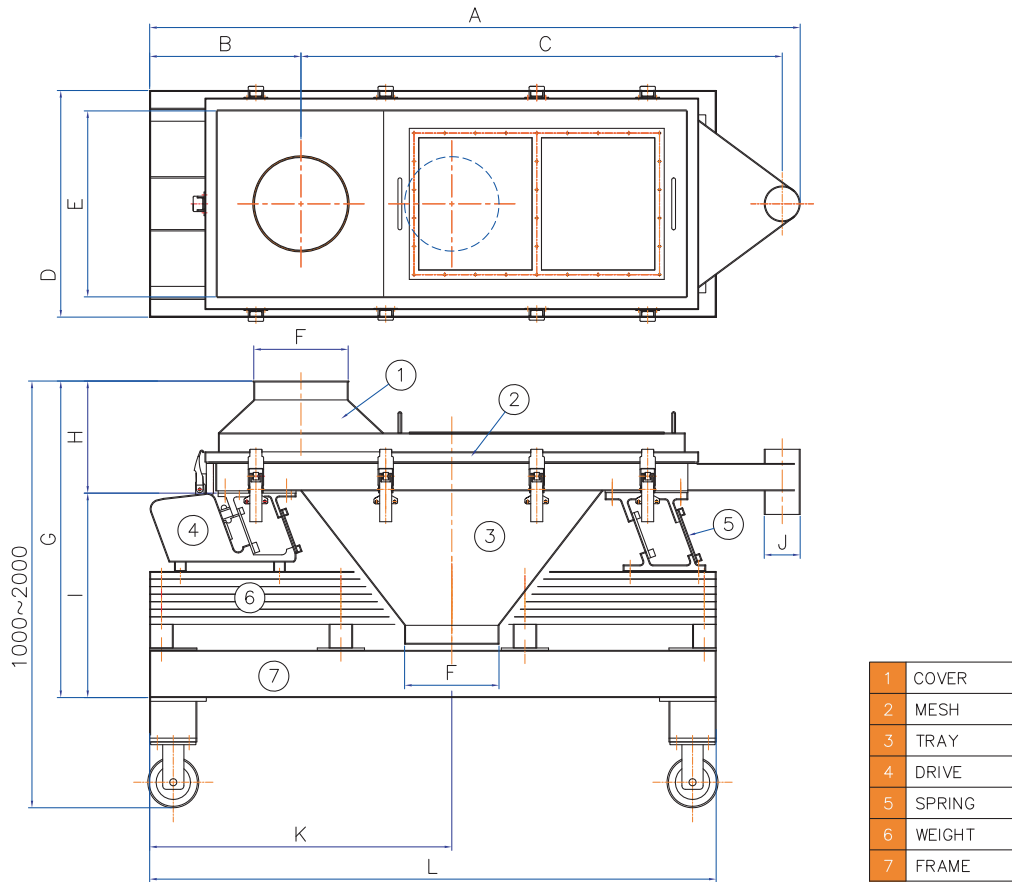

■ SPEC

	Capacity	Voltage	Ampere	Temperature	Amplitude
	M ³ /H	AC V	A (MAX)	°C	mm
DVS-200	1.0	110/220	2.0	-5~+50	0.1~3.0
DVS-400	2.0	110/220	2.0	-5~+50	0.1~3.0
DVS-600	3.0	110/220	2.0	-5~+50	0.1~3.0

■ DIMENSION

	A	B	C	D	E	F	G	H	I	J	K	L
DVS-200	1378	320	1020	280	200	φ150	670	237	433	φ76	640	1200
DVS-400	1378	320	1020	480	400	φ200	670	237	433	φ76	640	1200
DVS-600	1378	320	1020	680	600	φ200	670	237	433	φ76	640	1200



ARBO Engineering Inc.

3 Whitehorse Road, Unit 5, Toronto ON M3J 3G8 Canada

Tel: (416) 636-7057 Fax: (416) 630-9135 www.arbo-feeders.com