



Arbo Engineering Inc
 3 Whitehorse Rd, Unit 4&5
 Toronto, ON M3J 3G8
 Canada

Tel (416) 636-7057
 Fax (416) 630-9135

KDA-VS/28 Convertible Screw Feeder

Arbo's KDA-VS/28 twin screw feeder is ideal for low to moderate feed rates with a wide variety of materials. With a snap-off hopper to facilitate cleaning the VS/28 is easily converted to a single screw feeder. The internally driven horizontal hopper agitator makes the VS/28 suitable for more difficult materials which have a tendency to bridge or rathole. Special screw designs are available for materials from free flowing to sticky and cohesive.

The nominal capacity of the VS/28 is from around one half to several hundred pounds per hour depending on material density, flow characteristics and screw selection.



Capacity: ~ up to 10 ft ³ per hour	Hopper Capacity: 0.53 ft ³	Drive Motor: 0.5 hp (0.33 kw)
Agitator Motor: gear drive	Material: Type 304 Stainless	Screw Selection: Ø24 to 26mm

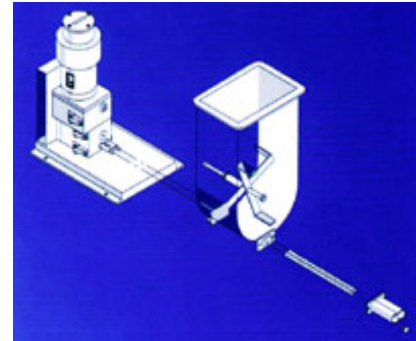
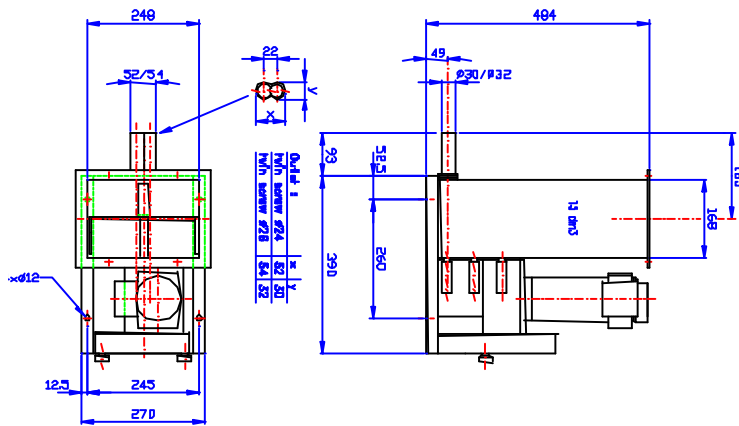

Options:
 Gravimetric adaptation
 Hi speed version

Horizontal or vertical outlet
 Water cooled hopper & outlet

Hopper cover with quick clamp
 Protective grid on hopper inlet